

4.4 Components and their characteristics

Circuits for investigating current / p.d. characteristics.

(i) Using a potential divider

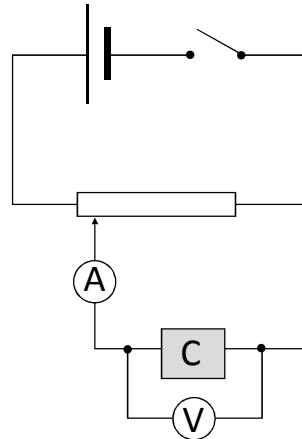

(ii) using a variable resistor

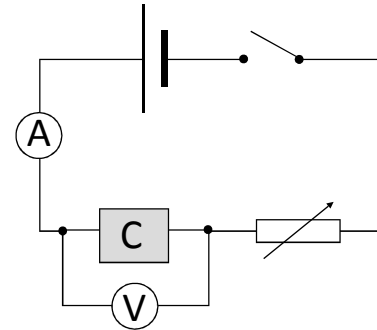

- ❖ The potential divider circuit is better because it allows the p.d. across the component C to be varied from zero up to the full p.d. of the battery.
- ❖ Characteristic curves are graphs of current through the component, (on the y-axis), against p.d. across the component, (on the x-axis).
- ❖ Occasionally V is plotted against I . Check carefully, particularly in exam questions, which way up the graph is.

4.4 Components and their character- istics

AS23

Examples of characteristic curves

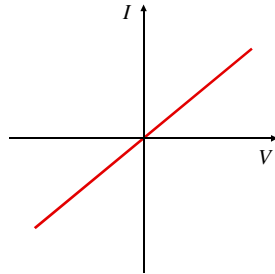

Metal wire at constant temperature
Resistance is constant. Components displaying straight-line I/V graphs are known as ohmic conductors.

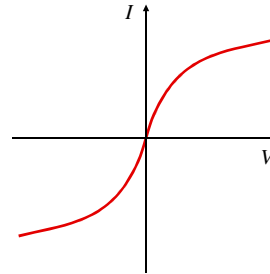

Filament lamp
The resistance of the metal filament increases as it becomes hotter. When it reaches maximum (white-hot) temperature, R remains constant.

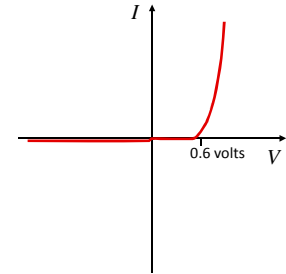

Semiconductor diode
The diode conducts with very little resistance in "forward bias," when the p.d. exceeds about 0.6V. In "reverse bias," only a tiny leakage current of a few μA flows.

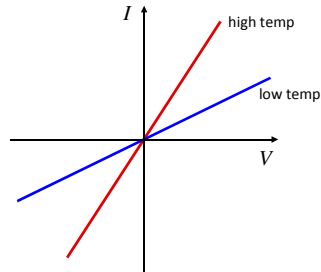

Thermistor at constant temperature

The thermistor is a semiconductor so, at high temperatures, its resistance is lower than at low temperatures.

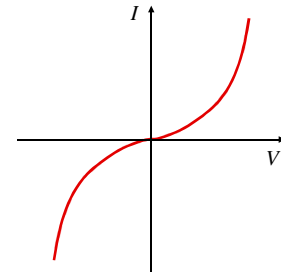

Thermistor whose temperature increases as the current increases